

KOMATSU®

D41E-6C D41P-6C

FLYWHEEL HORSEPOWER
82 kW **110 HP** @ 2300 rpm

OPERATING WEIGHT
D41E-6C: 10950 kg **24,140 lb**
D41P-6C: 11520 kg **25,400 lb**

D
41

CRAWLER DOZER



Photos may include optional equipment.

GALEO

D41E/P-6C Crawler Dozer

WALK-AROUND

The Komatsu SA6D102E-2A turbocharged and aftercooled diesel engine provides an output of 82 kW **110 HP**, with excellent productivity, and is Tier 2 EPA, EU, and Japan emissions certified.

Hydrostatic Driven Engine Cooling Fan controlled automatically, reduces fuel consumption and operating noise levels.

Left hand **joystick** controls all tractor motion. Right hand joystick controls all blade movements.

Gull-wing engine side doors for easy and safer servicing.

Super-angle blade facilitates transportation of D41-6

Blade tilt lines completely protected.

High capacity **Power Angle Tilt dozer** combines the highest power in its class with outstanding productivity.

Komatsu Hydroshift transmission offers single lever control of speed and directional changes (3 forward and 3 reverse).



D41E/P-6C

CRAWLER DOZER

Electronic Monitoring System prevents minor problems from developing into major ones.

New large, low noise cab (option) with viscous damping mounts provides unsurpassed operator comfort and visibility.

FLYWHEEL HORSEPOWER
82 kW 110 HP @ 2300 rpm

OPERATING WEIGHT
D41E-6C: 10950 kg 24,140 lb
D41P-6C: 11520 kg 25,400 lb

BLADE CAPACITY
PAT DOZER:
2.6 m³ - 2.9 m³ 3.4 yd³ - 3.8 yd³



Wet, single-disc brakes eliminates brake-disc adjustments for maintenance-free operation.

Steering clutch/brake PPC (Proportional Pressure Control) valve operates single disc steering clutches/brakes; providing light operating effort, and permits easy partial engagement of steering system.

Bolt-on sprocket for ease of maintenance.

Modular power train for increased serviceability and durability.

GALEO

Komatsu's highly productive, innovative technology, environmentally friendly machines built for the 21st century.

OPERATOR'S COMPARTMENT

Hexagonal Pressurized Cab (Optional)

This is another added comfort feature. Air filters and a higher internal air pressure combine to prevent external dust from entering the cab. In addition, the cab's hexagonal design provides excellent front, side, and rear visibility. Viscous damper cab suspension softens shocks for operator comfort and extends component life.



All steering, direction, and speed changes are made by a left-hand single joystick control. If the operator wants to move the machine forward and to the left, he simply moves the joystick forward and to the left. If he desires a gear change, he merely twists his wrist. The machine responds to the movement of the lever providing the operator with the feeling of natural control with Komatsu's joystick.

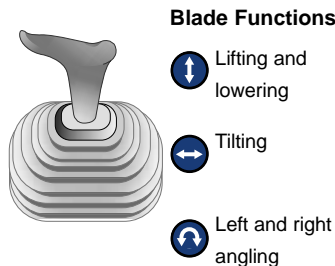
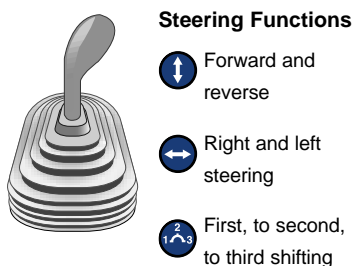

Low-Noise Design

For smoother riding comfort, power train components and hydraulic control valves are mounted to the frame with rubber pads to soften vibration and reduce noise.

Three-Stage Height Adjustable Armrests

Three-stage height adjustable arm rests and relocated fuel control lever provide comfortable operation and increase leg space.

Since the D41 employs joysticks, the walk-through operator compartment is uncluttered for smooth entry and exit. A suspension seat with backrest is standard equipment.



Three-stage height adjustable armrests

Easy-to-Operate Work Equipment Control Lever

With the Closed-center Load Sensing (CLSS) hydraulic system, blade lever stroke is directly proportional to blade speed, regardless of the load and travel speed. This results in superb, fine controllability.

Benefits of CLSS

- More precise and responsive operation due to the pressure compensation valve.
- Reduced fuel consumption by discharging only the required amount of oil from the pump.
- Compound operation such as blade raise, tilt and angle is easy due to CLSS parallel circuit with pressure compensation valve.

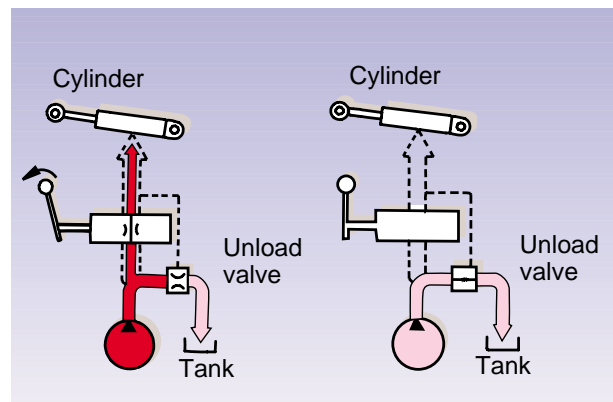

ENGINE AND HYDROSHIFT TRANSMISSION

Komatsu SA6D102E-2A Turbocharged Diesel Engine

Powerful Engine

A powerful SA6D102E-2A turbocharged diesel engine provides ample output of 82 kW **110 HP**. The engine power is transmitted smoothly to the final drives via a high-efficiency Hydroshift transmission. And this engine also meets EPA, EU Tier 2 emissions regulations, without sacrificing power or machine productivity.

Hydrostatic Driven Engine Cooling Fan

Fan rotation is automatically controlled depending on coolant and hydraulic oil temperature, saving fuel consumption and providing great productivity with a quiet operating environment.

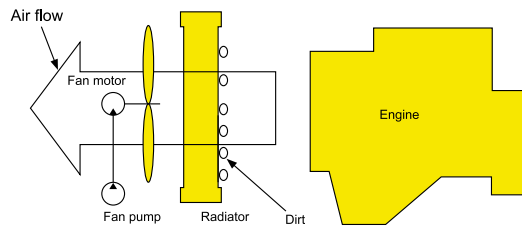

Hydroshift Transmission

The D41-6C is equipped with Komatsu's unique Hydroshift transmission, assuring smooth gear shifts, powerful traction and low fuel consumption. Its consists of a damper and planetary gear transmission. The Hydroshift transmission efficiently converts engine power to traction through direct drive transmission, yet it offers smooth, easy shifting through a power shift transmission.

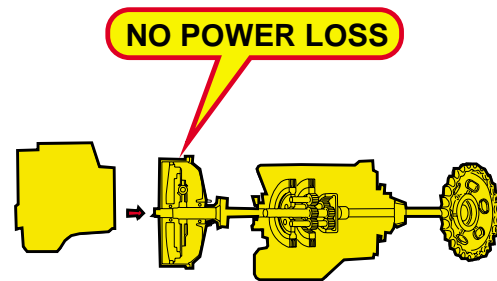

EXCELLENT GRADING ABILITY

Super Angle Blade— Blade Angles Responding to Job-Site Conditions

Komatsu's exclusive Super-angle blade angles freely to a maximum 55°, enabling fine grading in any job site conditions. The standard super-angle blade can be angled to a width smaller than the width of the track shoes. Therefore, the dozer is easy to transport and always ready to go to a new job-site.

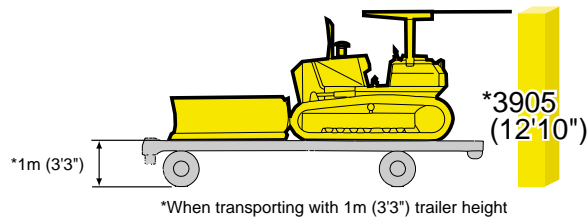
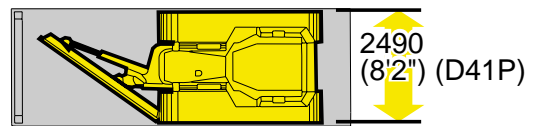
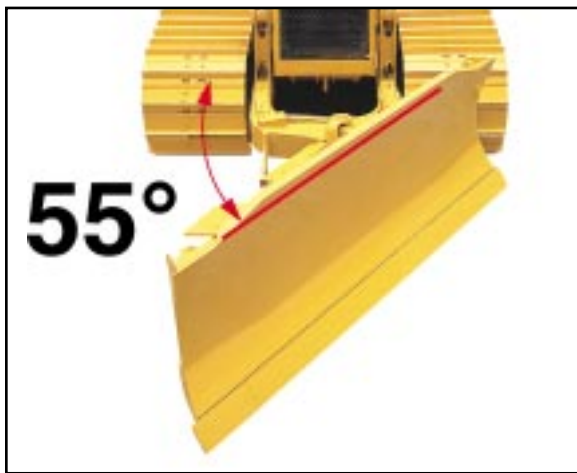

Outstanding Stability

The large ground contact area created by the long tracks and wide track gauges combine with a low center of gravity to make the D41-6C a stable and well balanced machine that can perform precise grading work even on rough or inclined terrain.

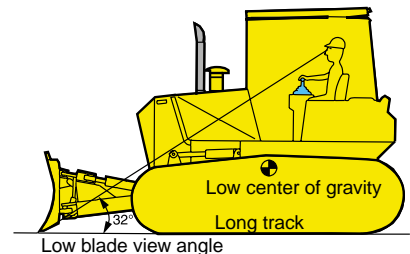

Exceptional Blade Visibility

The slim engine hood and well located operator seat provide excellent visibility of the blade. This clear blade visibility greatly increases grading efficiency and reduces operator guesswork. Finish grading and rough grading can both be performed easily, drastically reducing cycle times.

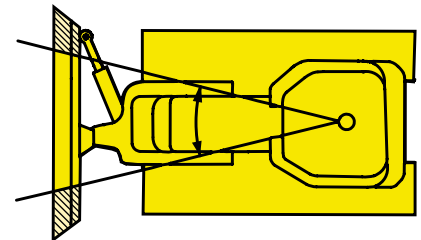

Active Steering Clutch/Brake

Fully hydraulically controlled single-disc steering clutches/brakes are operated by a PPC (Proportional Pressure Control) valve built-into the circuits, permitting easy partial engagement of the steering clutches/brakes system. In addition, with this PPC valve the lever stroke and operating effort are greatly reduced to minimize operator fatigue.

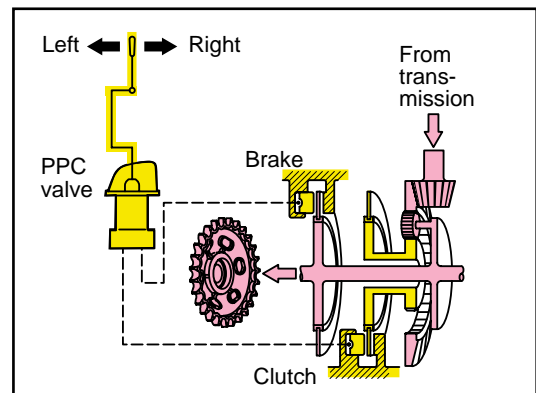

INCREASED RELIABILITY

Low Drive and Long Track Undercarriage

Komatsu's design is extraordinarily tough and offers excellent grading ability and stability.

Heavy Duty Undercarriage

Large link height, pins and bushing diameter and double-flanged track rollers ensure extended life of undercarriage. Remote greasing of the equalizer bar center pin facilitates serviceability.

Flat Bottom Frame

A **flat bottom frame** and the monocoque track frames provide good maneuverability in muddy terrain by preventing mud from building up under the frame.

Modular Designed Power Train Units

The modular design allows for easy removal and installation of any individual unit for shorter downtime.

Durability

Because fewer components mean greater reliability, we've designed a **simple hull frame** made of a thick, single plate. Track frames have a large-section construction for maximum rigidity. Even the box-section construction of the blade back beam is reinforced, all with durability in mind.

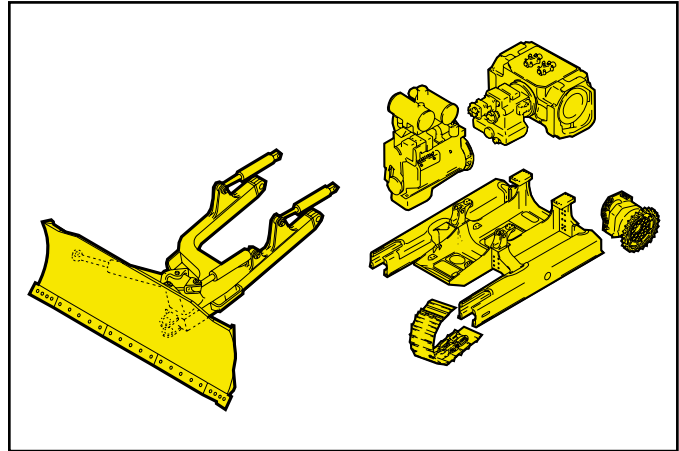

Electronic Monitoring System

An electronic monitoring system prevents minor problems from developing into major ones. All meters and gauges are controlled by a microcomputer, which provides a wide indication range for an easier, more precise reading.



- Charge Lamp
- Engine Oil Pressure Caution Lamp
- Engine Water Temperature Caution Lamp
- Engine Water Temperature Gauge
- Fuel Gauge
- Intake Air Heater Lamp
- Monitor Caution Cancel Switch
- Monitor Caution Lamp
- Service Meter
- Transmission Gear Indicator
- Fan Rotation Selector Switch
- Fan Operation Confirmation Lamp

MAINTENANCE FEATURES

Reversible Cooling Fan

If the machine is operating in adverse conditions, the operator can reverse the hydraulic driven engine cooling fan from inside the cab by turning on a switch on the control panel, facilitating cleaning of the radiator fins.



Gull-Wing Engine Side Covers

Engine servicing and daily service checks are made easy with the gas spring assisted full side opening gull-wing doors.

Wet, Single-Disc Brakes

Eliminates brake-disc adjustments for maintenance-free operation.

Reservoir



A radiator coolant reservoir makes it easier to check the coolant level and eliminates frequent refilling.

Test Ports



Oil pressure test ports for the power train are centralized on the right hand side of the operator platform for easy access.

SPECIFICATIONS



ENGINE

Model Komatsu SA6D102E-2A
 Type 4-stroke cycle, water-cooled, emissionized,
 direct injection, turbocharged, aftercooled engine
 Number of cylinders 6
 Bore 102 mm **4.02"**
 Stroke 120 mm **4.72"**
 Piston displacement 5.88 ltr **359 in³**
 Net flywheel horsepower*
 SAEJ1349 82 kW **110 HP** @ 2300 rpm
 DIN6270 82 kW **112 PS** @ 2300 rpm
 Net maximum torque 47 kg•m **340 ft lb** @ 1300 rpm

Direct injection fuel system. All-speed mechanical governor.
 Forced lubrication driven by gear pump. Full-flow for lube purification. Dry-type air cleaner with automatic dust evacuator and dust indicator. 5.5 kW/24V electrical starter motor. 60 A/24V alternator. 100 Ah/2 x 12V batteries.

* Net flywheel horsepower output for standard engine (SAE J1349) including air cleaner, alternator (not charging), water pump, lubricating oil pump, fuel pump, muffler, and fan.



HYDROSHIFT TRANSMISSION

Komatsu's unique HYDROSHIFT transmission with planetary gears is hydraulically controlled. Efficient power flow and simplified direction and speed changes. Joystick control of gears (3 forward and 3 reverse), directional and steering changes. Gearshift lock lever and neutral safety switch prevent machine from accidental starts.

Travel speed	Forward		Reverse	
1st	2.4 km/h	1.5 mph	3.0 km/h	1.9 mph
2nd	4.4 km/h	2.7 mph	5.5 km/h	3.4 mph
3rd	7.6 km/h	4.7 mph	9.4 km/h	5.8 mph

Rated drawbar pull	D41E-6	D41P-6
Forward 1st	102 kN/10380 kgf/ 22,880 lb	101 kN/10350 kgf/ 22,820 lb
Forward 2nd	52.1 kN/5310 kgf/ 11,710 lb	51.8 kN/5280 kgf/ 11,640 lb
Forward 3rd	26.2 kN/2670 kgf/ 5,890 lb	25.9 kN/2640 kgf/ 5,820 lb
Max. drawbar pull	144 kN/14740 kgf/ 32,500 lb	144 kN/14700 kgf/ 32,410 lb



STEERING

Joystick controls for all directional movements. Pushing the joystick forward results in forward machine travel, while pulling it rearward reverses the machine. Simply tilt the joystick to the left to make a left turn. Tilt it to the right for a right turn.

Wet, single-disc steering clutches are hydraulically actuated. A PPC valve integrated into steering circuit facilitates smooth, shockless steering control.

Minimum turning radius:
 D41E-6 2.4 m **7'10"**
 D41P-6 2.6 m **8'6"**

As measured by track marks on ground.



FINAL DRIVE

Spur gear single-reduction, final drives increase tractive effort. Bolt-on sprockets are for easy in-the-field replacement.



UNDERCARRIAGE

Suspension Rigid type
 Track roller frame Monocoque, box section, high-tensile-strength steel durable construction
 Number of carrier rollers (each side) 1
 Track shoes Lubricated tracks. Unique dust seals for preventing entry of foreign abrasive into pin-to-bushing clearances for extended service.
 Track tension is easily adjusted with a grease gun.

	D41E-6	D41P-6
Number of track rollers (each side)	6	7
Number of shoes (each side)	41	44
Grouser height	53 mm 2.1"	53 mm 2.1"
Shoe width (standard)	510 mm 20"	700 mm 28"
Ground contact area	25350 cm ² 3,930 in²	38430 cm ² 5,960 in²
Ground pressure (Tractor)	34.3 kPa 0.35 kgf/cm ² 4.98 psi	23.5 kPa 0.24 kgf/cm ² 3.41 psi
Track gauge	1790 mm 5'10"	1790 mm 5'10"
Length of track on ground	2485 mm 8'2"	2745 mm 9'0"



COOLANT AND LUBRICANT CAPACITY (REFILLING)

Coolant 28 ltr **7.4 U.S. gal**
 Fuel tank 250 ltr **66.0 U.S. gal**
 Engine oil 19 ltr **5.0 U.S. gal**
 Damper 1.1 ltr **0.3 U.S. gal**
 Transmission 19 ltr **5.0 U.S. gal**
 Bevel gear and steering system 74 ltr **19.6 U.S. gal**
 Final drive (each side) 13 ltr **3.4 U.S. gal**



OPERATING WEIGHT (APPROXIMATE)

Tractor weight:
 Including rated capacity of lubricant, coolant, full fuel tank, operator and standard equipment.
 D41E-6 8790 kg **19,380 lb**
 D41P-6 9370 kg **20,660 lb**

Operating weight:
 Including power angle tilt dozer, ROPS canopy, operator, standard equipment, rated capacity of lubricant, coolant, and full fuel tank.
 D41E-6 10950 kg **24,140 lb**
 D41P-6 11520 kg **25,400 lb**



DIMENSIONS

	D41E-6		D41P-6	
A	4880 mm	16'0"	4880 mm	16'0"
B	2300 mm	7'7"	2490 mm	8'2"
C	2900 mm	9'6"	2900 mm	9'6"
D	2675 mm	8'9"	2675 mm	8'9"
E	1790 mm	5'10"	1790 mm	5'10"
F	2485 mm	8'2"	2745 mm	9'0"
G	525 mm	1'9"	525 mm	1'9"
H	53 mm	2.1"	53 mm	2.1"
I	1830 mm	6'0"	1830 mm	6'0"
J	1824 mm	6'0"	1824 mm	6'0"

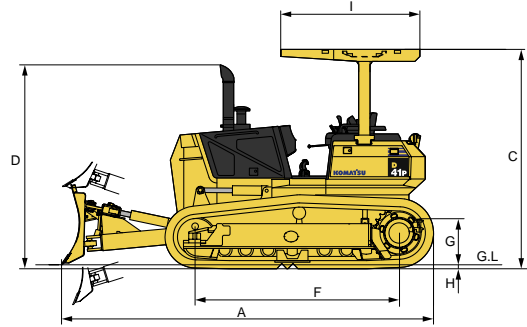
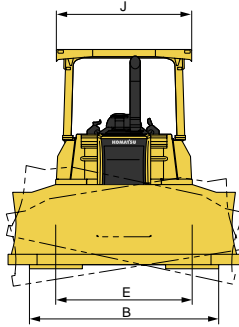

Ground clearance: 365 mm 1'2"



HYDRAULIC SYSTEM

Closed-center Load Sensing System (CLSS) designed for precise and responsive control and for efficient simultaneous operation.

Hydraulic control unit:

All spool control valves externally mounted beside the hydraulic tank. Gear-type hydraulic pump with capacity (discharge flow) of 86 ltr/min **22.7 U.S. gal/min** at rated engine rpm.

Relief valve setting 20.6 MPa /210 kg/cm² **2,990 psi**

Hydraulic cylinders Double-acting, piston type

	Number of cylinders	Bore
Blade lift	2	105 mm 4.13"
Blade tilt	1	110 mm 4.33"
Blade angle	1	130 mm 5.12"

Hydraulic oil capacity (refilling):

Power angle tilt dozer 44.0 ltr **11.6 U.S. gal**

Control valves:

3-Spool control valve for power angle tilt dozer.

Positions:

- Blade lift Raise, hold, lower, and float
- Blade tilt Right, hold, and left
- Blade angle Right, hold, and left

Additional control valve required for ripper.

Positions:

- Ripper lift Raise, hold, and lower



DOZER EQUIPMENT

D41-6 uses box construction of the back plate while using high-tensile-strength steel in moldboard to ensure extended service. Hydraulic hoses for blade angling and tilting are covered with steel plates for protection from damage.

	Overall Length With Dozer	Blade Capacity (SAE)	Blade Width x Height	Max. Lift Above Ground	Maximum Below Ground	Tilt Adjustment		Blade Angle		Additional Weight	
						L.H.	R.H.	L.H.	R.H.	Dozer equipment	Hydraulic control unit
D41E-6 Power Angle Tilt Dozer	4880 mm 16'	2.6 m ³ 3.4 yd³	3045 mm x 1060 mm 10' x 3'6"	1010 mm 3'4"	490 mm 1'7"	490 mm 1'7"	645 mm 2'1"	55°	25°	1580 kg 3,480 lb	220 kg 485 lb
D41E-6 Power Angle Tilt Dozer	4880 mm 16'	2.9 m ³ 3.8 yd³	3350 mm x 1060 mm 11' x 3'6"	1010 mm 3'4"	490 mm 1'7"	530 mm 1'9"	710 mm 2'4"	55°	25°	1660 kg 3,660 lb	220 kg 485 lb
D41P-6 Power Angle Tilt Dozer	4880 mm 16'	2.6 m ³ 3.4 yd³	3045 mm x 1060 mm 10' x 3'6"	1010 mm 3'4"	490 mm 1'7"	490 mm 1'7"	645 mm 2'1"	55°	25°	1580 kg 3,480 lb	220 kg 485 lb
*D41P-6 Power Angle Tilt Dozer	4880 mm 16'	2.9 m ³ 3.8 yd³	3350 mm x 1060 mm 11' x 3'6"	1010 mm 3'4"	490 mm 1'7"	530 mm 1'9"	710 mm 2'4"	30°	25°	1660 kg 3,660 lb	220 kg 485 lb

*: When equipped with the 3350 mm 11 ft width blade, maximum blade angle is 30 degrees and overall width is 2990 mm 9'10".



STANDARD EQUIPMENT FOR BASE MACHINE

- Air cleaner, double element with dust indicator
- Alternator, 60 ampere
- Backup alarm
- Batteries, 100 Ah/2 x 12V
- Cooling fan, hydrostatic driven
- Decelerator pedal
- Electronic instrument monitor panel
- Engine hood and gull-wing side covers
- Fenders
- Front pull hook
- High mount foot rests
- Hitch
- Hydraulics for Power Angle Tilt dozer
- Intake pipe with precleaner
- Lighting system, (includes 2 front, 1 rear)
- Locks, filler caps and covers
- Mono-lever steering with PPC
- Muffler with curved exhaust pipe
- Radiator reserve tank
- Rear cover
- ROPS mounting brackets
- Seat belt, retractable 78 mm **3"**
- Suspension seat, high back and reclining
- Starting motor, 5.5 kW/24V
- Track roller guard, center and end section
- Track shoe assembly
 - Sealed and lubricated track
 - 510 mm **20"** single grouser shoe (D41E)
 - 700 mm **28"** single grouser shoe (D41P)
- Underguards, crankcase and transmission
- Water separator



OPTIONAL EQUIPMENT

- Air conditioner
- AR track assembly (abrasion resistant bushings)
- Cab
- Cab accessories
 - Additional lights
- Hydraulics for ripper (D41E)
- Light, working, (cab additional)
- ROPS canopy
- Suspension seat
- Shoe, single grouser 560 mm **22"** (D41E)
Circular arc 700 mm **28"** (D41P)
- Track guard, full length
- Underguard, heavy-duty
- Vandalism protection cover for instrument panel
- ROPS CANOPY**
 - Additional weight 350 kg **770 lb**
 - Meets ISO 3471, SAE J1040 APR88 ROPS standards and ISO 3449 FOPS standard.
 - Roof dimensions:
 - Length: 1830 mm **6'0"**
 - Width: 1824 mm **6'0"**
 - Overall height: 2900 mm **9'6"**
- ROPS FOR CAB**
 - Additional weight 220 kg **485 lb**
 - Meets ISO 3471, SAE J1040 APR88 ROPS standards.
 - Dimensions:
 - Length: 530 mm **1'9"**
 - Width: 1670 mm **5'6"**
 - Overall height: 2900 mm **9'6"**
- STEEL CAB**
 - Additional weight 490 kg **1,080 lb**
 - Meets ISO 3449 FOPS standards.
 - All-weather, enclosed pressurized cab
 - Dimensions:
 - Length: 1760 mm **5'9"**
 - Width: 1380 mm **4'6"**
 - Height: 1590 mm **5'3"**
 - Overall height: 2780 mm **9'1"**
- MULTI-SHANK RIPPER (D41E)**
 - Additional weight (including hydraulic control unit): 810 kg **1,790 lb**
 - Beam length: 1555 mm **5'1"**
 - Maximum digging depth: 495 mm **1'7"**
 - Maximum lift above ground: 365 mm **1'2"**

SUPPORT

Count on Komatsu and your local distributor for the support you deserve. Our success depends on satisfying your need for productive equipment and supporting that equipment. That's why we have one of the largest and strongest heavy-equipment distributor organizations in North America. Their personnel are not only trained to help you select the equipment that is best-matched for your business but to support that equipment.



Finance Through its finance company, Komatsu can offer you a wide variety of financing alternatives designed to meet your needs. Programs include municipal leases for governmental agencies, conditional sales contracts, and leases with \$1 purchase options for customers interested in owning their equipment. Ask your distributor about Komatsu leasing. We offer finance and operating leases and the unique *Advantage Lease* which offers you predetermined purchase, return, and renewal options.



Parts Three computer-linked parts distribution centers provide fast access to anywhere in the U.S. and Canada. Most parts are available overnight. Plus, Komatsu distributors keep a large assortment of commonly used parts in stock for immediate access.



Remanufactured parts Save money and still have the same warranty as new parts at a fraction of the cost with like-new remanufactured parts.



Maintenance Take advantage of the experience we have gained and ask your distributor about our factory-supported programs including: regular scheduled maintenance, oil and wear analysis, diagnostic inspections, undercarriage inspections, training, special service tools, parts programs, and even a special software program to help your distributor keep track of and manage service-related data.

AESS624-01

©2003 Komatsu Printed in USA

DK8(5M)C

8/03 (EV-1)

KOMATSU®

440 N. Fairway Drive
P.O. Box 8112
Vernon Hills, IL 60061-8112

